

# ADDRESSING FUTURE COMMUNICATION NEEDS

In recent years, we have seen a massive deployment of smart metering systems in Europe. These systems require bi-directional telecommunication between the smart meters and the electricity distribution companies that, with the maximum guarantee of integrity and security, allow remote access to the electricity smart meters and flexible control of the demanded power.

One of the biggest difficulties faced by electricity distribution companies in the deployment of these systems was to achieve remote access from their central systems to every electricity smart meter installed in their customers' houses through the secondary substations as an instrumental telecommunications node in the architecture. The capillarity of the telecommunications network that needed to be deployed was very high. Distribution companies invariably chose one of two options: either based on the connectivity services offered by the public mobile operators or they extended their telecommunications networks to provide connectivity to their customers' houses based on the infrastructure already deployed, i.e. power cables, making use of powerline communications (PLC). Specifically, the medium voltage (MV) grid has been used to reach secondary substations with broadband PLC, and the low voltage (LV) grid has used narrower band PLC systems.

Overall, the metering systems already deployed in Spain, France, Portugal and Italy, among others, utilise PLC and share a distributed architecture.

## New challenges for PLC networks

In November 2016, the European Commission proposed a series of measures included in the Clean Energy Package to provide a fair deal for consumers. Consumers are to play a central role in the energy markets of the future. To do so, in the future consumer should have better access to reliable energy price comparison tools; and have the possibility to produce and sell their own electricity.

If we add to this central consumer role in the electricity market, the commitment from the EU to achieve global leadership in distributed renewable energies, then distribution companies should adapt to meet the new challenges posed to them. That is, not only those related to traditional network operations, but also those concerning energy management from the point of view of supply – renewable energy sources, distributed along its MV and LV grid – from the point of view of the demand and the more dynamic role of the consumer.

This evolution will lead to significant advances in the digitalisation of the MV and LV grids, and it can be foreseen that two main evolution vectors will demand new requirements for the telecommunications networks currently deployed that will rule their future evolution:

- Distribution companies will require real-time monitoring of the MV and LV

network; a clear example can be found in integration periods of smart meter demand profiles. In 2017 European demand profiles have a period of integration of 1 hour. For distribution operators to be able to act effectively on demand, it will be necessary to have more frequent integration periods (up to 5 minutes). In this way, electricity distribution companies will be able to optimise their investments in network assets, by applying demand flexibility policies, and investing in storage systems.

- A second very important vector is found in the final consumers, who should have information in real time (1-5 seconds) relating to their power consumption/generation. In this way, they will be able to carry out efficient energy management policies and, if necessary, be able to actively participate as an agent of the electricity market.

These two evolution vectors will have a great impact on the requirements imposed on the telecommunications services in the already deployed PLC networks.

- On the one hand, the volume of data that the new services will demand from telecommunications networks will grow by several orders of magnitude. As noted above, if a demand profile with time integration period generates 24 energy values per day (active import energy), in the same period of time, decreasing the integration period to five minutes, implies an increase of the number of energy values (288).

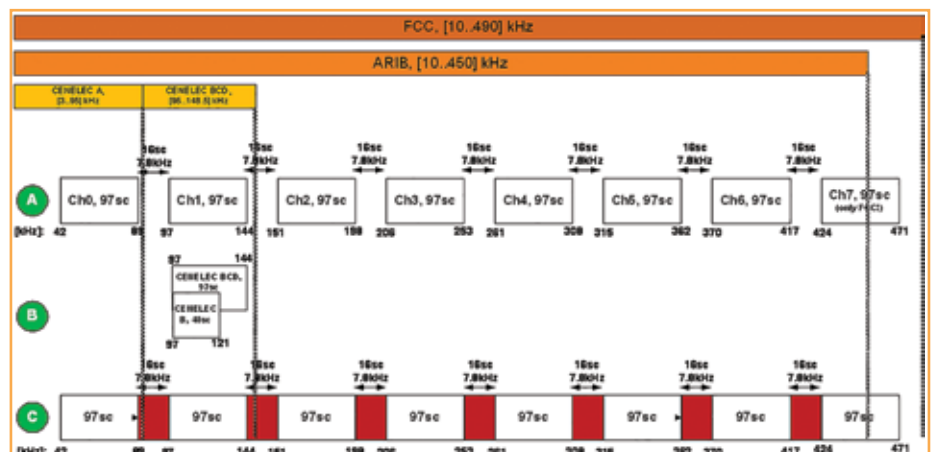

Figure 1. The new PRIME 1.4 physical layer definition with eight channels.

*PLC is the natural connectivity interface for any device plugged to the grid.*

- Access to the data stored in the smart meters should be more frequent. It is not the same as accessing smart meters for billing purposes, where accessing once a day is more than enough. The requirements imposed for active participation in a demand management market will require access every 5 – 15 minutes.
- Finally, services of a different nature will also require access to the telecommunications network. Both the needs of direct access from home energy management systems to the information

stored in the electricity smart meters and the new monitoring and remote control services required by the new assets to deploy on the network (storage and distributed generation), need to be highlighted.

**PLC networks are ready to cope with these new challenges**

PLC is the natural connectivity interface for any device plugged to the grid, be it a smart meter or an IED (intelligent electronic device). Both BPL and narrower band PLC can be combined to design architectures that cope with the new needs from the grid.

BPL is today connecting tens of thousands of secondary substations through the MV grid in architectures combining commercial and utility telecommunications. BPL can even be extended further down the grid (LV), reaching closer to the buildings where customers' smart meters are installed.

PRIME Technology (Powerline Intelligent Metering Evolution) has consolidated its PRIME 1.4 specification. PRIME is a PLC telecommunications technology developed by the PRIME Alliance (<http://www.prime-alliance.org>), and an international ITU G. 9904 Standard.

Many distribution companies such as Iberdrola, Enega, EDP, Gas Natural Fenosa and EVN Bulgaria have deployed their metering systems based on PRIME. These deployments are based on the previous 1.3.6 version that specifies a modulation scheme OFDM (Orthogonal Frequency Division Multiplexing) in the band CENELEC A (from 3 to 95 kHz) which, in Europe, is reserved for distribution companies (EN 50065-1). PRIME 1.3.6 occupies the frequency band between 40 and 90 kHz, obtaining data throughputs of up to 21.4 kbps in its most robust mode.

The PRIME 1.4 telecommunications standard provides the ability to multiply the available bandwidth by eight. To do this, PRIME 1.4 extends its operation to the 500 kHz with a new physical layer definition with eight channels. (see Figure 1.)

Telecommunication networks based on PRIME technologies have a clear evolutionary path, leveraging the experience with PRIME 1.3.6 in current smart metering deployments. PRIME 1.4 copes with the future requirements PLC telecommunication networks should meet to assure consumers will play a central role in the new electricity market. **SEI**

**PRIME ALLIANCE**

Supporting Members:



Embracing Open **PRIME & RF** Standards and **BPL** alternatives

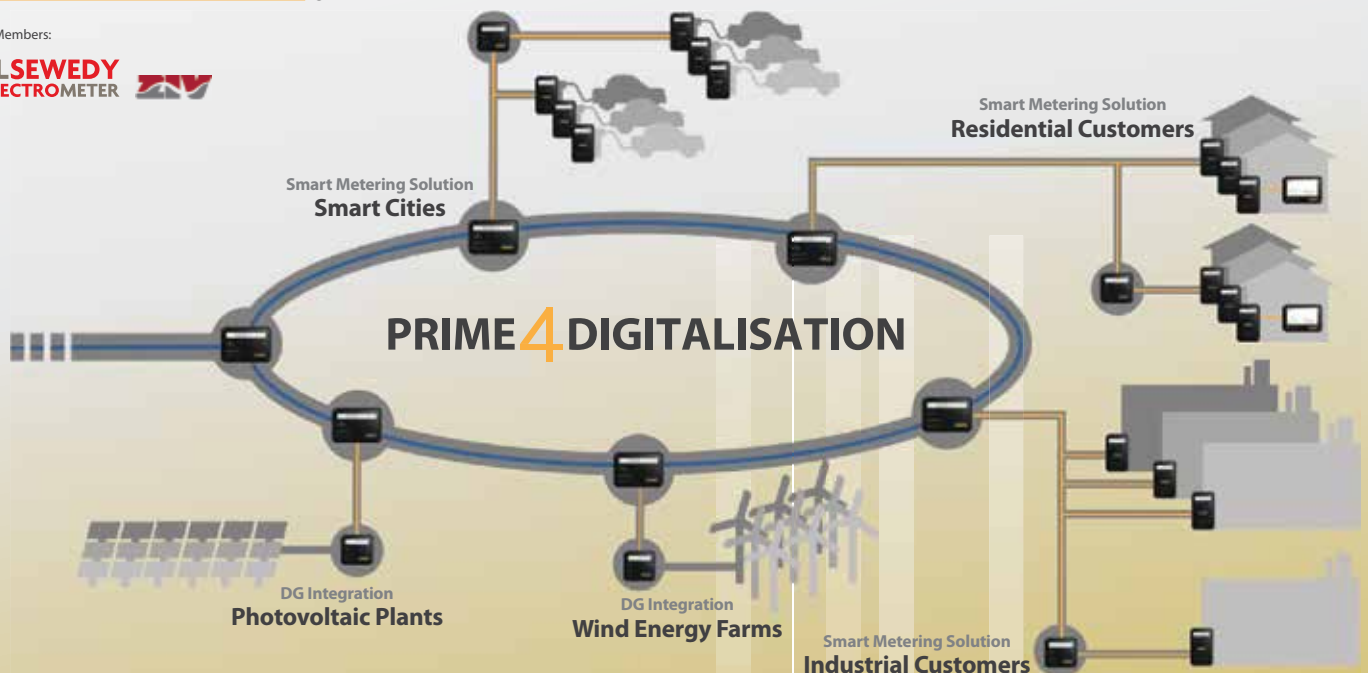

Providing end-to-end solutions to **MULTI UTILITIES, SMART CITIES and INDUSTRIAL CUSTOMERS**

Discover more - [www.prime-alliance.org](http://www.prime-alliance.org)